

## BCS-DMQE1500IR3-G(-B)

5Mpx IR eyeball camera HDCVI/AHD/TVI/ANALOG with 3.6mm lens



### Key features:

- Sensor 1/2.5" 5Mpx PS CMOS
- Resolution 2704×1950@20fps
- 4 system: HDCVI/AHD/TVI/ANALOG
- IR-cut filter with auto switch (ICR)
- Functions AGC, AWB, AES
- Digital Noise Reduction DNR
- Wide Dynamic Range D-WDR
- Screen menu OSD
- Fixed lens 3.6mm
- IR Leds distance up to 30m
- Protection IP66
- Working environment -20°C ~ +60°C
- Output selectable from switch
- Power supply 12V DC(±10%)
- **BCS-DMQE1500IR3-B** – version in white

### Dimensions:

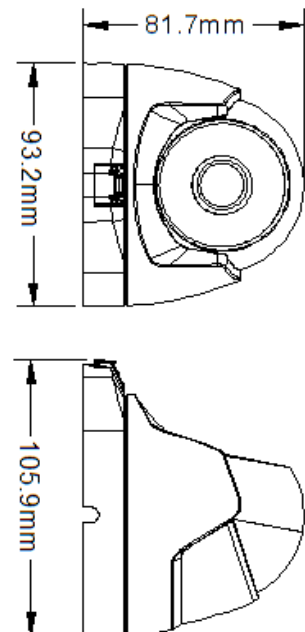

**BCS-DMQE1500IR3-G(-B)**

5Mpx IR eyeball camera HDCVI/AHD/TVI/ANALOG with 3.6mm lens

**Specification:**

Scanning system	Progressive Scan
System	HDCVI/AHD/TVI/ANALOG
Sensor	1/2.5" 5Mpx CMOS K03 + FH8538M
Pixels	2704(H) × 1950(V)
Resolution	5Mpx(2704×1950)@20fps; 4Mpx(2560×1440)@25/30fps; 1080P(1920×1080)@25/30fps; 720P(1280×720)@25/30fps
Video out	HDCVI/AHD/TVI/ANALOG 1 V p-p, composite, BNC, 75 Ohm
Minimum illumination	B/W: 0Lux (IR On)
S/N ratio	35dB
White balance	AWB (Auto/Manual)
Lens	3.6mm F2.0
Backlight compensation	D-WDR
Shutter	Auto
Gain control	(AGC) Auto
Noise Reduction	2D DNR
Day/Night	IR-cut filter with auto switch (ICR)
IR	IR Led distance up to 30m
Power supply	12V DC (±10%)
Power consumption	<5W
Working environment	-20°C ~ +60°C, IP66
Weight	0.3kg
Dimensions	93.2mm(105.9mm) × 81.7mm